

Maintenance Manual

REFRIGERATIVE AIR DRYER
CT1960

General

Instruction will help user to operate equipments safely, exactly, and then by the best ratio of utility and price. To operate equipments according to its instruction will prevent danger, reduce maintenance fee and non-working period, i.e. improve its security and last its endurance period.

Instruction must append some regulations which were issued by specified countries about accident prevention and environment protection. The user must get instruction and operators must read it. Carefully and be in accordance with it while operating this equipment, e.g. arrangement, maintenance (Checking and fix) and transport.

Except the above regulations, meanwhile general technical regulations about safety and normally working must be obeyed.

Guarantee

Before operation, familiarity with this instruction is necessary. Supposing this equipment will be used out of its usage mentioned in the instruction, we will not be responsible for its safety during operation.

Some cases will not be upon our guarantee as follows:

- non-consistency resulted by improper operation
- non-consistency resulted by improper maintenance
- non-consistency resulted by using ill-suited auxiliary
- non-consistency resulted by unusing original spare parts supplied by us
- non-consistency resulted by changing gas supplying system arbitrarily

Ordinary compensation orange will not be expanded by the cases mentioned above.

Safe Operation Specification

Danger: operation regulations must be strictly obeyed.

Technical modification

We preserve our right to modify the technology for this machine but not to inform the user during the product technology improvement process.

A. Attention to the installation

- (A) Standard Requirement for this air dryer: No Ground bolt is needed but the foundation must be horizontal and solid, which furthermore it should also concern the drainage system height and drainage channel can be set.
- (B) The distance between the air dryer and other machines should not less than one meter by way of conveniently operation and maintenance.
- (C) The air dryer is absolutely forbidden to be installed outside of a building or some sites with direct sunshine, rain, high temperature, bad ventilation, heavy dust.
- (D) While assembling, some avoidance as follow: too long pipeline, too many elbows, little pipe size in order to lessen pressure drop.
- (E) At the inlet and outlet, bypass valves should be externally equipped for checking and maintenance while in trouble.

- (F) Special attention to the power for the air dryer:
 1. Rated voltage should be within $\pm 5\%$.
 2. Electric cable line size must concern current value and line length.
 3. The power must be specially supplied.

- (G) The cooling or cycling water must be intererated. And its pressure must not be less than 0.15Mpa, its temperature not higher than 32°C.

- (H) At inlet of the air dryer, a pipeline filter is suggested to be equipped which may prevent solid impurities which size not less than 3 μ and oil from polluting HECH copper tube surface. This case may affect heat-exchanging ability.

- (I) The air dryer is suggested to be installed following the back cooler and gas tank on the process in order to debase Compressed-air inlet temperature of the air dryer. Please carefully handle the air dryer utilities and its working years. Assuming any problem and doubt, don't hesitate to inquire us.

B. The maintenance requirement for Freezing Type Drier.

It is highly necessary to maintenance the air dryer. Proper use and maintenance may guarantee the air dryer to accomplish its usage but also last endurance time.

- (A) Maintenance to surface of the air dryer:

It mainly means cleaning outside of the air dryer. While performing that, generally with wet cloth first then by dry cloth. To directly spray it with water should be avoided. Otherwise electronic parts and instruments may be damaged by water and its insulation will be played down. In addition, no gasoline or some volatile oil, thinner some other chemical agents can be used for cleaning. Or else, those agents will depigmentize, deform the surface and flake away the painting.

- (B) The maintenance for automatic drainer
User should examine the water-draining condition and remove the garbage adhered to the filter meshwork to prevent the drainer from being blocked and failing to drain.
Notice: Only suds or cleaning agent may be used for cleaning the drainer. Gasoline, toluene, spirits of turpentine or other erodent are prohibited to be used.

- (C) Supposing extra drain valve is equipped, user should drain at least twice everyday at set time.

- (D) Inside Wind-cooling condenser, the spacing between two blades is only 2~3mm and easily to be blocked by dust in air, which will baffle heat radiation. In this case, user should spray it termly generally by compressed air or brush it by copper brush.

- (E) Maintenance for water-cooling type filter:

Water filter will prevent solid impurity from entering condenser and guarantee nice heat exchange. User should clean filter meshwork termly in order not to make water badly cycle and heat fails to radiate.

- (F) Maintenance for internal parts:
During non-working period, user should clean or collect dust termly.
- (G) Good ventilation is necessary around this equipment at any moment and the air dryer should be prevented from exposing in sunshine or heat source.
- (H) During the process of maintenance, the refrigeration system should be protected and for fear to be demolished.

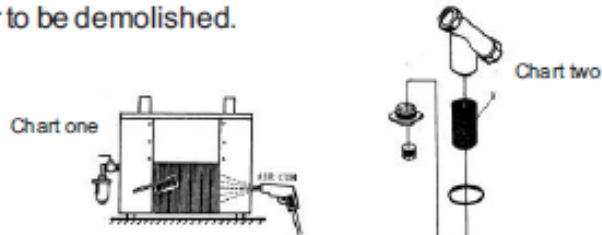

- ✘ Chart one: Cleaning illustration for condensers at the back of Freezing Type Drier cleaning points for automatic drainer. As shown in the charts, disassemble the drainer and dip it in suds or cleaning agent, brush it by copper brush. Caution: Gasoline, toluene, spirits of turpentine or other erodent are prohibited to be used while performing this step.
- ✘ Chart two: Water filter disassembling illustration.

C. Series of Freezing Type Drier operation process

- (A) Examination before starting up
 1. Examine if the power voltage is normal.
 2. Checking the refrigerant system: Watch high and low pressure gauge on the refrigerant which may reach a balance at a definite pressure which will be fluctuated by the surrounding temperature, usually it is about 0.8~1.6Mpa.
 3. Checking if the pipeline is normal. The inlet air pressure should not be higher than 1.2Mpa (except some special type) and its temperature should not be higher than the set value while selecting this type.
 4. Supposing water cooling type is used, well then user should check if the cooling water can satisfy with the requirement. Its pressure is 0.15~0.4Mpa and temperature should be less than 32°C.
- (B) Operation Method
Instrument control panel specification.
 1. High pressure gauge which will show condensation pressure value for the refrigerant.
 2. Air outlet pressure gauge which will indicate the compressed air pressure value at outlet of this air dryer.
 3. Stop button. When press this button, this air dryer will stop running.
 4. Start button. Press this button, this air dryer will be connected with power and start running.
 5. Power indication light (Power). While it is light, it indicates the power has been connected with this equipment.
 6. Operation indication light (Run). While it is light, it shows this air dryer is running.
 7. High-low pressure protective on-off indication light for refrigerant. (Ref H.L.P). While it is light, it shows that protective on-off has been released and this

equipment should be stopped running and fixed.

8. Indication light while current overload (O.C.TRIP). When it is light, it indicates the compressor working current is overload, hereby overload relay has been released and this equipment should be stopped running and fixed.

(C) Operation Procedure for this FTP:

1. Switch on the on-off, and power indication light will be red on the power control panel.
2. If water cooling type is used, the inlet and outlet valves for cooling water should be open.
3. Push the green button (START), operation indication light (Green) will be light. The compressor will start running.
4. Check if the operation of the compressor is in gear, i.e. if some abnormal sound can be heard or whether the indication for high-low pressure gauge is well-balanced.
5. Assuming everything is normal, open the compressor and the inlet and outlet valve, air will flow into air dryer and meanwhile close the by-pass valve. At this moment air pressure indication gauge will show air outlet pressure.
6. Watch for 5~10 minutes, the air after being treated by air dryer can meet using requirement when low-pressure gauge on the refrigerant will indicate pressure is:
R22: 0.3~0.5 Mpa and its high-pressure gauge will indicate 1.2~1.8Mpa.
R134a: 0.18~0.35 Mpa and its high-pressure gauge will indicate 0.7~1.0 Mpa.
R410a: 0.48~0.8 Mpa and its high-pressure gauge will indicate 1.92~3.0 Mpa.
7. Open copper globe valve on the automatic drainer, where after the condensed water in the air will flow into the drainer and will be discharged.
8. Air source should be closed first when stop running this equipment, afterwards press the red STOP button to switch off air dryer and cut off the power. Open the draining valve and then drain completely waste condensed water.

(D) Pay attention to some proceeding while air dryer is on operation:

1. Prevent air dryer from running long time with no load as possible.
2. Prohibit from starting and stopping air dryer during a short time for fear refrigerant compressor is damaged.

D. Typical trouble analysis and settlement for air dryer

The freezing dryer troubles mainly exist in electric circuits and refrigeration system. The results of these troubles are system is shut down, reduction of refrigerating capacity or equipment damage. To locate the trouble spot correctly and take practical measures concern with theories of refrigerant and electrical techniques, some thing more important is experiences in practice. Some troubles may caused by several reasons first of all analyze the refrigerant equipment synthetically to find out the solution. In addition some trouble is caused by improper use or maintenance, this is called "false" trouble, so the right way to find the trouble is practice.

The common troubles and disposing measures are as follows:

1. The air dryer can not work:

Cause:

- a. No power supply.
- b. Circuit fuse melted.
- c. Wire disconnected.
- d. Wire has loosed.

Disposal:

- a. Check power supply.
- b. Replace the fuse.
- c. Find the unconnected spots and repair it.
- d. Tightly connect.

2. The compressor can't work.

Cause:

- a. Fewer phase in power supply, improper voltage.
- b. Bad contacts, the power is not put through.
- c. High & low pressure (or voltage) protective switch problem.
- d. The over heat or over load protective relay problem.
- e. Wire disconnection in control circuit terminals.
- f. Mechanical trouble of compressor, such as jammed cylinder.
- g. Supposing the compressor is started by capacitor, probably the capacitor has be damaged.

Disposal:

- a. Check power supply, control power supply in proper voltage.
- b. Replace contactor.
- c. Regulate voltage switch set value, or replace damaged switch.
- d. Replace thermal or over load protector.
- e. Find out disconnected terminal and reconnect it.
- f. Replace compressor.
- g. Replace starting capacitor.

3. The refrigerant high pressure is too high cause pressure switch released (REF H,L,P,TRIP indicator goes on).

Cause:

- a. The inlet air temperature is too high.
- b. The heat exchange of wind-cooling condenser is not good, may caused by insufficient cooling water flow or bad ventilation.
- c. Ambient temperature is too high.
- b. Overfilling of refrigerant.
- c. Gases get in the refrigerating system.

Disposal:

- a. Improve the heat exchange of back cooler to lower the inlet air temperature.
- b. Clean pipes of condenser and water cooling system and increase cool water cycling amount.
- c. Improve ventilation condition.
- b. Discharge surplus refrigerant.
- c. Vacuumize the refrigerant system once more, fill some refrigerant.

4. The refrigerant low pressure is too low and cause pressure switch release (REF H LPTEIP indicator goes on).

Cause:

- a. No compressed air flows for a period of time.
- b. Too small load.

- c. The hot air bypass valve is not open or bad.
- d. Insufficient refrigerant or leaking.

Disposal:

- a. Improve air consumption condition.
- b. Increase air flow and heat load.
- c. Regulate hot air bypass valve, or replace bad valve.
- d. Refill refrigerant or find leaking sports, repair and vacuumize once more, refill refrigerant.

- 5.** The operation current is overload, cause compressor over-temperature and the over-heat relay released (O,C,TRIP indicator goes on).

Cause:

- a. Over heavy air load, bad ventilation.
- b. Too high ambient temperature and bad ventilation.
- c. Too big mechanical friction of the compressor.
- d. Insufficient refrigerant cause high temperature.
- e. Over load for the compressor.
- f. Bad contact for main contactor.

Disposal:

- a. Lower the heat load and inlet air temperature.
- b. Improve ventilation condition.
- c. Replace lubrication grease or the compressor.
- d. Fill refrigerant.
- e. Reduce start & stop times.

- 6.** Water in evaporator has frozen, this manifestation is that no action of the automatic drainer for long time. Consequently when the waste valve is opened, there are ice particles blown out.

Cause:

- a. Little air flow, low heat load.
- b. The heat air bypass valve is not opened.
- c. The inlet of the evaporator has been jammed and too much ater-collection, herewith ice particles has dumped and make air badly flow.

Disposal:

- a. Increase compressed-air flow quantity.
- b. Adjust heat air bypass valve.
- c. Dredge the drainer and completely drain the waste water in the condenser.

- 7.** Dew point indication is too high.

Cause:

- a. Inlet air temperature is too high.
- b. Ambient temperature is too high.
- c. Bad heat exchange in air cooling system, the condenser choked; in water cooling system water flow is not sufficient or water temperature is too high.

- d. Over much air flow but over low pressure.
- e. No air flow.

Disposal:

- a. Improve heat radiation in back cooler and lower inlet air temperature.
- b. Lower ambient temperature.
- c. To wind-cooling type, clean the condenser.
As for water-cooling type, remove the furring in the condenser.
- d. Improve air condition.
- e. Improve air consumption condition for compressor.
- f. Replace dew point gauge.

8. Too much pressure drop for compressed air.

Cause:

- a. Pipeline filter has choked.
- b. The pipeline valves haven't been totally open.
- c. Little size pipeline, and too many elbows or too long pipeline.
- d. The condensed water has been frozen and cause gas tubes to be jammed in evaporator.

Disposal:

- a. Clean or replace the filter.
- b. Open all valves which air must flow by.
- c. Meliorate air flow system.
- d. Follow as above mentioned.

9. The Freezing Type Dryer may normally run whereas low-effectively performs:

It is mainly because the changed case caused the refrigerating system condition transformed and the flow rate is out of the regulation range of the expanding valve. Here it is necessary to adjust it manually.

When adjust valves, the turning range shall be little by 1/4—1/2 circle at one time. Where after operate this equipment for 10—20 minutes, check the performance and by it to decide if readjustment is needed anymore.

As we know that the air dryer is complex system which consists of four big units and many accessories, that are interactively effective to each other. Hereby in case trouble occurs, we shall not only pay attention to one part but also take overall inspection and analysis to eliminate suspicious parts step by step and finally find out the cause.

In addition when repair or maintenance works performed for the air dryer, user shall pay attention to preventing refrigeration system from being damaged, especially the damages to capillary tubes. Otherwise refrigerant leaking may engendered.

CT1960 USER GUIDE

Versión: h161031

1. Technique Index

Temperature display range: $-20 \sim 100^{\circ}\text{C}$ The resolution is 0.1°C

Power supply: $220\text{V} \pm 10\%$

Temperature sensor: NTC $R_{25}=5\text{k}\Omega$, $B(25/50)=3470\text{K}$

2. Operating Guide

2.1 Meaning of the index lights on the panel



Index light	Light	Flash
Power	on	--
Remote Interface	Switch machine controlled by external input	--
Alarm	--	Alarm state
Compressor	The compressor output is open	Compressor is the output, are in protection of delay
Fan	The fan output open	--
Drain	Drain output is open	--

2.2 Meaning of the LED display

Alarm signal will alternate display temperature and warning code. (A xx) To cancel the alarm need recharge the controller. Display code as follow:

Code	Meaning	Explain
A11	External alarm	Alarm from external alarm signal, refer to the internal parameter code "F50"
A12	Low pressure alarm	From external alarm signal alarm, stop and lock, need to unlock switch machine
A13	High pressure alarm	
A21	The dew-point sensor fault	The dew-point sensor broken-line or short circuit (The dew-point temperature display "OPE" or "SHr")
A22	Condensation sensor fault	The condensation broken-line or short circuit (Press "6" will display "SHr" or "OPE")

A31	The dew-point temperature fault	If alarm occurred in the dew-point temperature higher than the set value, can choose whether closing down or not (F11). The dew-point temperature alarm will not occurred when compressor starts in five minutes.
A32	Condensation temperature fault	If alarm occurred in the condensation temperature higher than the set value. Only the alarm don't stop.

2.3 Temperature display

After power on self-test, the LED display the dew-point temperature value. When press on " ", it will display the temperature of condenser. Reverse will back to display the dew-point temperature.

Manual mode of drainage

Press and hold " " button to start the drainage, loosen the end drainage.

2.4 Cumulative working hours display

Pressing on the " " at the same time, will display the compressor accumulated operational time. Unit: hours.

2.5 User basic parameter Settings

In the condition of temperature, press "Set" key to switch in turn display (F61) drainage time, (F62) drainage time interval, (F82), local and remote. Long press "Set" key to make its flashing, can through the "5, and 6" key change parameter values, then press "Set" key to confirm changes.

2.6 Higher level operation

Long press "M" 5 seconds to enter parameter setting condition. If have set the command, will display word "PAS" to hint import the command. Using press " " to import the command. If the code is right, it will display parameter code. Parameter code as followed table:

Category	Code	Parameter name	Setting range	Factory setting	Unit	Remark
Temperature	F11	Dew-point temperature warning point	10 - 45	20	°C	It will warning when the temperature higher than the set value. Only the alarm don't stop.
	F12	Condensation temperature warning point	42 - 65	55	°C	
	F18	Dew-point sensor amendment	-20.0-20.0	0.0	°C	Correction the evaporator temperature probe error
	F19	Condensation sensor amendment	-20.0-20.0	0.0	°C	Correction the condenser probe error

Compressor	F21	Sensor delay time	0.2 - 10.0	3	MIN	
Antifreezing	F31	Start antifreezing demand temperature	-5.0-10.0	2	°C	When the dew point temperature is below the set to start
	F32	Antifreezing return difference	1 - 5	2	°C	When the dew point temperature is higher than F31 + F32 stop
Fan	F41	The fan pattern	OFF 1-3	1	-	OFF: Close the fan 1. Fan is condensing temperature control 2. Fan by external pressure switch control 3. The fan has been running
	F42	Fan start temperature	32 - 55	42	°C	When the condensation temperature is higher than the set open, lower than the "set-return difference" when closed
	F43	Fan close temperature return difference	1 - 10	2	°C	
Alarm	F50	External alarm mode	0 - 4	0	-	0: without external alarm 1: always open, unlocked 2: always open, locked 3: always closed, unlocked 4: always closed, locked
Drain	F61	Drainage time	1 - 6	3	Sec	Output first 3 seconds, then 3 minutes to stop output, infinite loop
	F62	Interval time	0.1 - 6.0	3	min	
System means	F80	Password	OFF 0001-9999	OFF	-	OFF means no password 0000 System means clearing password
	F82	Remote/local control switch machine	0 - 1	0	-	0: local 1: Remote
	F83	Switch machine state memory	YES - NO	YES	-	
	F85	Display the compressor accumulated operational time	-	-	hour	
	F86	Reset compressor accumulated operational time	NO-YES	NO	-	No: not reset YES: reset
Testing	F98	Reserved				
	F99	Test-se not If	This function can attract all relays in turn, and please don't use it when the controller is running!			
	End	Exit				

3. Basic Operating Principle

3.1 Compressor control

Press power key to switch to "on", open the compressor, if the distance is the last stop protected downtime has been less than (F21), the delay boot, compressor indicator lights flashing at this time. When detected alarm (high and low pressure alarm, external input alarm), the compressor shut down. Only the alarm after the cancellation, shutdown boot again to start the compressor.

3.2 Drainage control

Manual drainage: Holding down the " " button for drainage, , loosen the " " button the drainage is stop.

Automatic drainage: Automatic drainage (F61) and drainage by drainage time interval (F62) control, The controller After electrify an infinite loop

"Draining" output is not affected by the shutdown/running state.

Operational control

"Run" output disconnect when turned off, closed in on.

3.3 Fan control

In order to prevent irrespective persons from changing the parameters, you can set a password (F80), and if you have set a password, the controller will hint you to enter the password after you press the key "M" for 5 seconds, you must enter the correct password, and then you can set the parameters. If you don't need the password, you can set F80 to "0000". Notice that you must remember the password, and if you forget the password, you can not enter the set state.

The fan can be set to "pressure" by the input signals to control, open the fan when closed, when disconnected off the fan.

3.4 External alarm

When external alarm occurs, stop the compressor and fan. External alarm signal has 5 modes (F50): 0: without external alarm, 1: always open, unlocked, 2: always open, locked; 3: always closed, unlocked; 4: always closed, locked. "Always open" means in normal state, external alarm signal is open, if closed, the controller is alarm; "Always closed" is on the contrary. "Locked" means that when external alarm signal becomes normal, the controller is still in the alarm state, and it needs to press any key to resume.

3.5 Anti-freezing control

Antifreeze output controlled by dew point temperature, in the running state, detect dew point temperature is lower than the set point (F31), open the antifreeze electromagnetic valve; Temperatures to rise to "set point temperature (F32) +", close the antifreeze solenoid valve.

3.6 Stop pressure balance

Compressor will open frost valve when stop the machine (30 seconds) to carry on the pressure balance, to prevent compressor opens locked-rotor next time. Controller is powered on when he carried out the operation, to prevent a short stop complex caused by blocked.

3.7 Password

In order to prevent irrespective persons from changing the parameters, you can set a password (F80), and if you have set a password, the controller will hint you to enter the

password after you press the key "M" for 5 seconds, you must enter the correct password, and then you can set the parameters. If you don't need the password, you can set F80 to "0000". Notice that you must remember the password, and if you forget the password, you can not enter the set state.

4. Wiring Diagram

The input wiring diagram

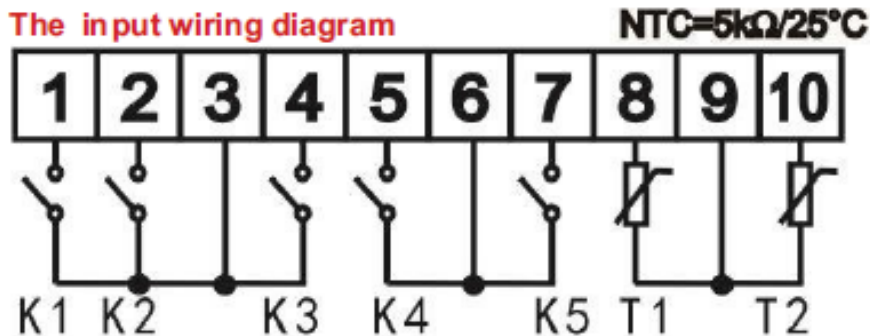

K1: pressure K2: remote K3: fault K4: low K5: high
T1: condensation T2: dew

The output wiring diagram

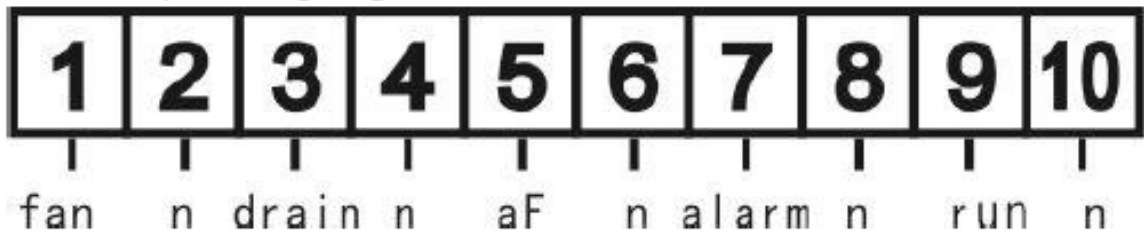

5. Notes

Please use the temperature sensor allocated by our company.

If compressor power is less than 1.5HP, can direct control by internal relay. Otherwise need to connect ac contactor.